

# ASP-1HD-AM

## ASP-1 Heavy-Duty Automation Module

Installs **External** O-Rings ranging from 0.056" I.D. to 1.051" I.D.\*\*

AIS is the world's leading manufacturer of O-ring and seal installation machines and the only company to utilize the revolutionary radial stretch technique, a solution that significantly enhances durability, simplifies installation, minimizes damage, and ensures **improved seal integrity**. Since 1977, AIS has built precision assembly equipment trusted across automotive, hydraulic, aerospace, medical, and industrial manufacturing. Every machine is designed, engineered, and built in Erie, PA.

The **ASP-1 Heavy Duty Automation Module** is a purpose-built external seal installation system engineered for the demands of **high-throughput** automated assembly lines. Where standard machines are sized for operator-paced production, the ASP-1 HD is built for the punishment of continuous-duty operation, every component selected for long service life under sustained cycle loads. A reinforced **heavy-duty** frame delivers maximum rigidity with minimal deflection over time. **Allen-Bradley** controls provide the reliability, familiar interface, and broad integration support that plant engineers and maintenance teams depend on.

The **modular** architecture supports fast configuration changes, capacity expansion, and straightforward serviceability without extended downtime, including an optional **2-Up Configuration** with dual head assemblies that **doubles output speed**. An open-access layout keeps tooling changes, diagnostics, and routine maintenance fast and accessible. The ASP-1 HD-AM is integration-ready, engineered for drop-in installation within new or existing automation systems.



### Ideal For:

O-Rings

Cup Seals

Back-Up Rings

Quad Seals

Teflon Seals

and More!



## ASP-1HD-AM Optional Features and Upgrades

**2-Up Configuration** – Available with 2 head assemblies for **DOUBLE** the output speed!

**O-Ring Detection** – A sensor verifies the presence of an O-ring on the mandrel during each machine cycle. If no O-ring is detected, a warning light is triggered, and the machine automatically shuts down.

**Low Lube Reservoir Sensor** – A sensor monitors the lubricant level and activates a warning light when the reservoir is running low.

**Low Bowl Sensor** – A sensor monitors the O-ring or seal level and triggers a warning light when the feeder bowl is running low..

**O.D. Lubricator** – Applies lubrication to the O-ring's outer diameter, facilitating smoother installation in the next stage of your process.

**Medical Package** – Stainless steel components specifically suited for medical and cleanroom applications.

**Variable Placement Module** – A rotary actuator with a transfer mandrel places seals onto parts in vertical or other orientations.

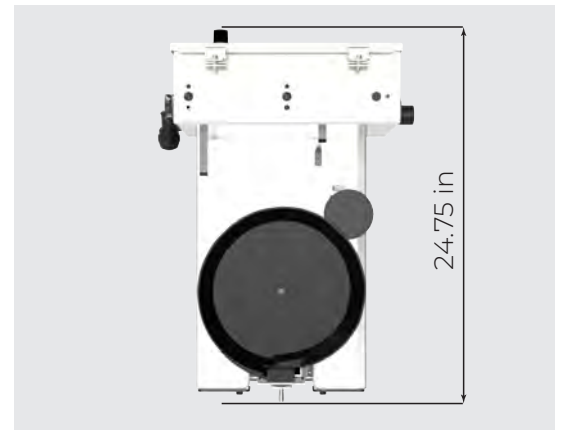

### STANDARD ASP-1HD-AM DIMENSIONS

#### Machine Specifications:

115 VAC, 60Hz (Other voltages upon request.) 65-90 psi (6.025 bar) air supply. CE package available.

- Accommodates O-Rings ranging from 0.150" (3.810mm) to 1.156"\* (29.362mm) Outside Diameter\*\*
- Cycle rates of up to 60/120 per minute (3600/7200 per hour)
- Allen-Bradley controls standard
- Compact, less than 2 square feet
- Reinforced heavy-duty frame for continuous-duty operation
- Designed for guarded/interlocked automated systems
- Open chassis designed for simple maintenance

\* For applications with O-Rings larger than 1.156" O.D. please see our ASP-2 machine.

\*\* Dependent upon ratio of cross section to Outside Diameter and O-Ring material.



4238 West 12th Street, Erie, PA 16505

[www.aisoring.com](http://www.aisoring.com)

814-838-2270